



Manual for
drilling motor

BBM 33 LL extra

230 V

Valid from 03.2018

Art.-Nr. 200924

Subject to alterations



All rights reserved

DR. BENDER GmbH • D-75382 Althengstett • Tel 07051-9291-0 • Fax 07051-9291-91

Our website address is: <http://www.dr-bender.de> • eMail: info@dr-bender.de

Conformity Declaration

DR.BENDER GmbH

Innovative Elektrowerkzeuge



EC declaration of conformity (EG-RL 2006/42/EG)

Hereby the manufacturer

Dr. Bender GmbH
Industriestrasse 22
75382 Althengstett

declares for the product

BBM 33 LL extra

The named product conforms to the following Council Directives on approximation of laws of the EEC Member States:

- Council Directive for machinery (2006/42/EC)
- Council Directive for Electromagnetic compatibility (EMC) (2004/108/EG)
- Low Voltage Guide Lines (2006/95/EG)

Conformity with the requirements of this Directives is testified by complete adherence to the following standards:

EN 50144-1
EN 50144-2-1
EN 55014-1
EN 61000-3-2
EN 61000-3-3
EN 55014-2
EN 61029-1

The instructions contained in the operating manual for installation and start up the machine have to be followed.

Authorised Person for Documentation:

Min Wei
c/o Dr. Bender GmbH
Industriestrasse 22
75382 Althengstett
Germany

DR.BENDER GmbH
IndustriestraÙe 22
D-75382 Althengstett
Tel. 07051/9291-0, Fax 07051/9291-91

Althengstett, 30.07.2018

Min Wei, Managing Director

This Declaration does not include Assurance of Product Properties.
The Safety Instructions of the enclosed Product Documentation have to be respected.

Contents

	page
Conformity declaration	2
Contents	3
1.0 Symbol- and Pictograph description	4
1.1 Function description	4
2.0 General instructions	5
2.1 Application	5
2.2 Safety	5
3.0 Transport and storage	6
3.1 Transport	6
3.2 Storage	6
4.0 Main dimensions and technical data	7
4.1 Dimensions	7
4.2 Technical data	7
4.3 Noise emissions and vibrations [EN 50144]	8
5.0 Commissioning	8
5.1 Changing gear	9
5.2 Safety coupling	9
5.3 Core bits	9
5.4 To change a core bit	9
6.0 Safety instructions	10
7.0 Servicing and care	11
7.1 Daily care	11
7.2 After approx. 150 hours of use	11
7.3 After approx. 250 hours of use	11
7.4 Quarterly	11
8.0 Speed adjustment dependent on the cutting speed	12
9.0 Warranty	13
10.0 General safety instructions	14
11.0 Spare parts list	16
11.1 Stone drilling machine complete	16
11.2 Motor complete	18
11.3 Gear complete	20
11.4 Connection cables and accessories	22



Warning

It is compulsory to observe the safety instructions included in this manual!

Special designs and versions may differ from the standard models in terms of their technical details. If any points are unclear, we urgently recommend that you contact DR.BENDER GmbH, indicating the machine type and machine number.

1.0 Symbol- and Pictograph description



This sign tells you rules, if you not pay attention for this your health and the function of the machine is in danger. You have no warranty if the machine breaks down because you not looking about this.

1.1 Function description

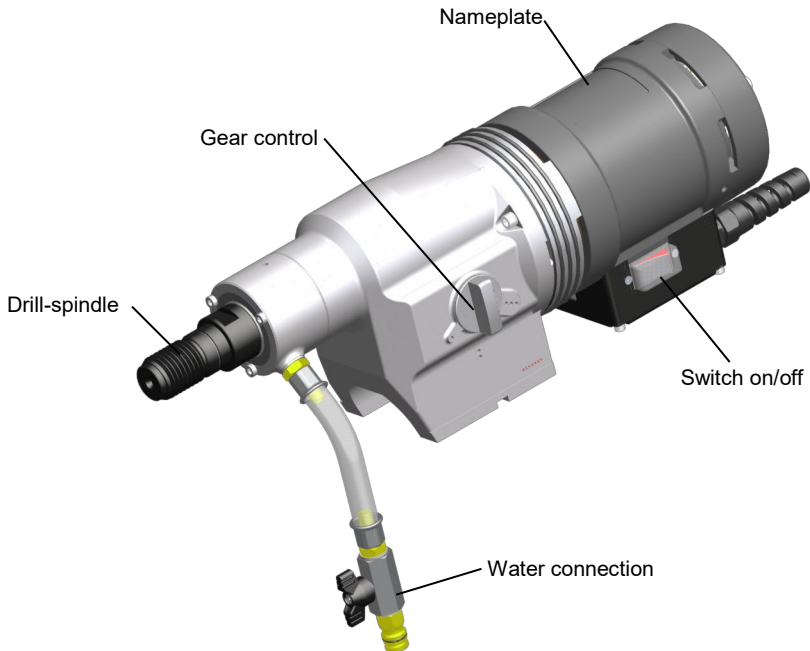

2.0 General instructions

2.1 Application

The core drills can be used for the purposes outlined by the data on the model plate. If you are using special machines, the details in the quotation and order confirmation also apply.

The core drills are supplied as standard in protection class I, only this can guarantee the full high quality production of the residual current-operated circuit-breaker or PRCD switch.

If you use suitable core bits, you will be able to drill holes in the most diverse material types:

- Concrete (even if it contains thick reinforcement steel)
- Sandstone and limestone
- All building materials for solid walls
- Asphalt floors

The core drills comply with the regulations issued by the "Stone and Earth" Professional Association issued in July 1989. They are machines of category II, which means that they must be placed on stands and be stable (pursuant to DIN 57100 or VDE 0100), the stand must be equipped with

- a reversing block, and
- a water suction device.

The machine must be connected to the 230 V mains

- direct using a personal safety switch (residual current-operated circuit-breaker or PRCD), or
- using a coded (1h) plug to a safety box (IP 44) with a residual current-operated circuit-breaker.

2.2 Safety



Warning

Before using the machine for the first time, check that the conformity of the data on the model plate with the mains voltage and frequency. Voltage deviations of $\pm 5\%$ and/or voltage deviations of $\pm 2\%$ are permissible. Repairs must only be completed by quality persons who have suitable training and qualifications.

The following points are to be given special attention:

- the technical data and details of the permitted use of the machine (commissioning, ambient and operating conditions) which are set out in the catalogue, the operating manual, the model plate data and other product information,
- the relevant accident prevention regulations
- the correct use of tools
- the use of personal safety equipment

3.0 Transport and storage

3.1 Transport



Warning

The core drills are to be checked for signs for transport damage on receipt. Any damage must be documented in writing.

3.2 Storage

If possible, the storage site should be dry, clean and have a constant temperature. To ensure that the film of lubricant in the bearings and sealing system is not lost, the motor shaft should be turned through several revolutions by hand after a lengthy period of storage, for example at monthly intervals. The roller bearings in the motors should be replaced (or regreased) if the period between delivery and commissioning is over four years. If the machines are stored in adverse conditions, this period may differ considerably.

4.0 Main dimensions and technical data

4.1 Dimensions

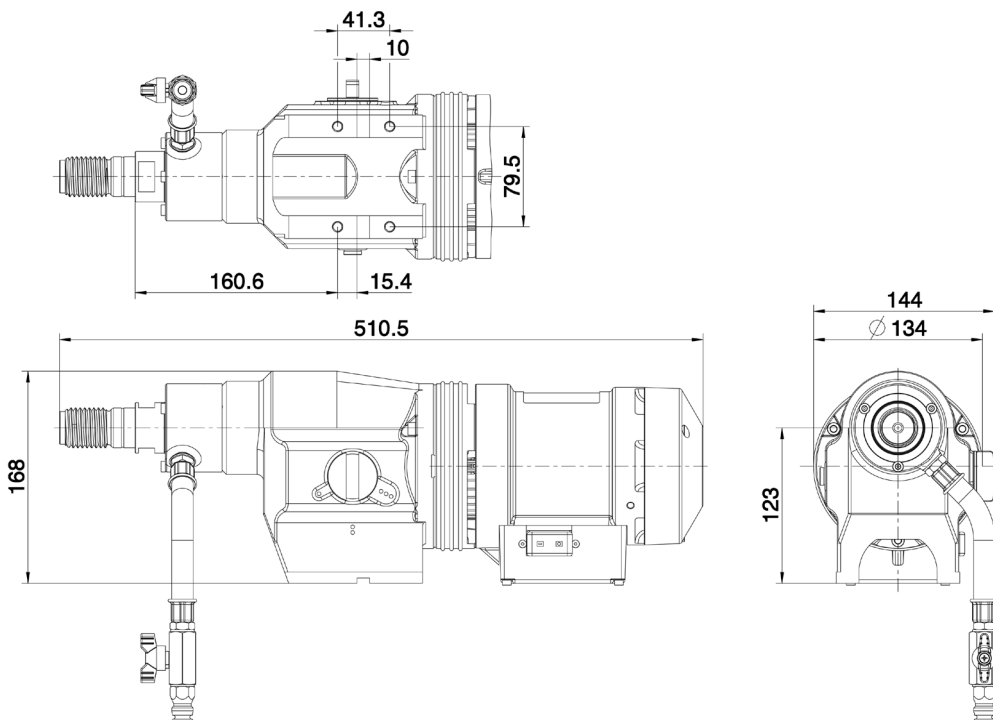

4.2 Technical data

Rated voltage	230	V
Current consumption	15,9	A
Power requirement	3300	W
Frequency	50 – 60	Hz
Idling speed	315 / 720 / 1090	min^{-1}
Full speed	155 / 375 / 650	min^{-1}
Output rating	2400	W
Torque	142 / 68 / 38	Nm
Drilling diameter	50 – 470	mm
Weight	13,2	kg
Core bit connection	UNC 1 ¼	"
Overload coupling torque	260	Nm

4.3 Noise emissions and vibrations [EN 50144]

Noise level	Noise level	Vibration
dB(A)	dB	m/s ²
82	96	< 2,5

5.0 Commissioning

Check that the mains voltage is identical to the voltage specified on the model plate.

Secure the core drill and the water collector to the drilling stand with its reverse block. The drilling stand should be as rigid as possible and have precise, low-play guides. Ensure that the core drill axis is parallel to the axis of the drilling stand.

Insert the core bit and set the speed. The setting instructions are on page 12.

Connect the water supply. Important: Do not exceed the maximum water pressure of 3 bar.

Connect the core drill to the mains using a residual current-operated circuit-breaker box and 1 h coded plug or a PRCD safety switch. Only use three-core extension cables with a protective conductor and an adequate cross-section. If the cross-section is too low, you may lose excessive power and result in the motor and cable overheating. An extension cable must have an overload cut-out switch. Recommended cable cross-sections:

Rated current = 15,9 A							
Cable length	m	7,5	15	25	30	45	60
Cable cross section	mm ²	2,5	2,5	2,5	2,5	2,5	4

Ensure that you have sufficient cooling water for drilling. Only use pure tap water, do not use dirty or waste water. Adjust the feed speed to the core bit diameter and the drive rating of the core drill so that the rated current is not exceeded.

5.1 Changing gear



Warning

Never change gear using force and only do so when the machine is slowing down or at a standstill.

To change into the next higher or lower gear, move the gear-change lever through an angle of approx. 50°. If necessary (if the gear is difficult to engage), turn the drive spindle briefly by hand until the gear engages easily.

Do not use any tools (pliers, hammer, etc.) to change gear since otherwise gear damage is a natural consequence.

5.2 Safety coupling

The values set out in the table are theoretical values and may be used to provide a rough guide for gear changing. Since a whole range of other parameters also plays a major role in adjusting the speed, we cannot offer any guarantee if the tool is damaged when using the values in the table. Drilling work for which the speeds are outside the range of the core drill (values printed in italics), should only be completed with extreme care and by trained personnel.

5.3 Core bits

All core bits with a connection thread of 1 ¼ " UNC can be used.

Adapters can be supplied to allow core bits with other connection systems to be used.

Only use core bits that are suitable for the type of stone.

You will keep the core drill in good condition if you only use core bits that are concentric and not deformed ones.

Ensure that the diamond segments have an adequate undercut against the core bit body.



Warning

To use wrong tools or accessories is danger for your life.

5.4 To change a core bit

The drill spindle has a right-handed thread.

Always use a 32 mm open-ended spanner to hold against the drill spindle.

Never release the core bit with (hammer) blows since this will damage the core drill.

The core bit can be removed more easily if you apply a little waterproof grease to the drill spindle thread.

6.0 Safety instructions



Important

Only use the core drill under supervision. Disconnect the mains plug and check that the switch has been turned off,

- if you intend to leave the core drill unsupervised,
- for attachment and disconnection work,
- if the voltage drops (below 200 V),
- for adjustments or for fitting an accessory,

Switch off the machine if it stops for any reason. This will prevent its starting suddenly when it is not under supervision.

Do not use the tool if

- part of the casing is missing or defective,
- If water drips out of the overflow hole, stop work and have the core drill inspected by an authorised service contractor.
- Only drill above your head with suitable safety equipment (water collector), RCD and transformer protection class II.
- Connect dust extraction if required.
- After a fault do not switch on the machine again until the core bit can be turned easily.
- Check the area you wish to drill with a line detector to prevent drilling through electric cables, water or gas lines, etc.
- the switch, lead or plug connector has suffered damage (conduct a visual inspection every day).
- Cooling water must not be allowed to ingress into the motor or the electrical components when operating the core drill in any position.

Do not expose the tool to rain and use not in humidity or wet environment. Use a good lightning. Do not use the tool near flammable fluids or gase air mixes.

7.0 Servicing and care



Warning

Disconnect the mains plug before commencing any servicing or repair work. You must have the core drill checked by an electrician after every repair (statutory regulation pursuant to VBG4 since 1.1.1990).

7.1 Daily care

Ensure that no water is emitted from the overflow hole. This will cause gear damage and may adversely affect the electrical safety of the core drill. If water is emitted, see assistance from an authorised service outlet.

Visual inspection for damage to the switch, connection lead or plug connector

After completing the drilling work clean the core drill. Grease the core bit mounting thread. The ventilation slits must always be clean and open. Ensure that during the cleaning process, no water gets into the core drill.

To maintain the seal, oil the drilling spindle as follows

- Disconnect the core drill from the water supply. Open the water connector shut-off cock, add several drops of oil, close the shut-off cock, add several drops of oil to the overflow hole and turn the machine briefly by hand.

7.2 After approx. 150 hours of use

After the first 150 hours of use, the gearbox oil must be changed.

7.3 After approx. 250 hours of use

Have the carbon brushes checked, and replaced if necessary, by an electrician.

Avoid adjusting the carbon retaining springs.

Only use original spare parts

7.4 Quarterly

Have the cable, switch and plug connectors inspected by a specialist (regulation pursuant to VBG4) and document this inspection. Changing the gearbox oil will produce a considerably increase in the service life of the gear.

8.0 Speed adjustment dependent on the cutting speed

	3	4	5	6	7	[m/s]
50	1146	1528	1910	2292	2674	3rd gear
60	955	1273	1592	1910	2228	3rd gear
65	881	1175	1469	1763	2057	3rd gear
70	819	1091	1364	1637	1910	3rd gear
75	764	1019	1273	1528	1783	3rd gear
80	716	955	1194	1432	1671	3rd gear
85	674	899	1123	1348	1573	3rd gear
90	650	849	1061	1273	1485	3rd gear
95	603	804	1005	1206	1407	3rd gear
100	573	764	955	1146	1337	3rd gear
110	521	694	868	1042	1215	3rd gear
120	477	650	796	955	1114	3rd gear
130	441	588	735	881	1028	3rd gear
140	409	546	682	819	955	3rd gear
150	375	509	650	764	891	3rd gear
160	358	477	597	716	836	3rd gear
170	337	449	562	674	786	3rd gear
180	318	424	531	650	743	3rd gear
190	302	402	503	603	704	3rd gear
200	286	375	477	573	650	3rd gear
220	260	347	434	521	608	2 or 3
240	239	318	398	477	557	2 or 3
260	220	294	375	441	514	2 or 3
280	205	273	341	409	477	2 or 3
300	191	255	318	375	446	2 or 3
320	179	239	298	358	418	2 or 3
340	169	225	281	337	393	2 or 3
360	159	212	265	318	375	2nd gear
380	155	201	251	302	352	1 or 2
400	143	191	239	286	334	1 or 2
420	136	182	227	273	318	1 or 2
440	130	174	217	260	304	1 or 2
460	125	166	208	249	291	1 or 2
480	119	159	199	239	279	1st gear
500	115	155	191	229	267	1st gear
520	110	147	184	220	257	1st gear
540	106	141	177	212	248	1st gear
560	102	136	171	205	239	1st gear
580	99	132	165	198	231	1st gear
600	95	127	159	191	223	1st gear
620	92	123	155	185	216	1st gear
640	90	119	149	179	209	1st gear
660	87	116	145	174	203	1st gear
680	84	112	140	155	197	1st gear
Bit capacity ø		concrete	concrete	rock		
[mm]		reinforced				

The values set out in the table are theoretical values and may be used to provide a rough guide for gear changing. Since a whole range of other parameters also plays a major role in adjusting the speed, we cannot offer any guarantee if the tool is damaged when using the values in the table. Drilling work for which the speeds are outside the range of the core drill (values printed in italics), should only be completed with extreme care and by trained personnel.

9.0 Warranty

In keeping with our terms of sale, we offer a warranty for 24 months from the date of sale. This refers to the free repair of material and workmanship defects, which were verifiably caused before the sale.

An original purchase document must always be submitted in case of a warranty claim. It has to contain the full address of the dealer, the date of purchase and the type designation of the product. The operating instructions of the particular product and the safety instructions must have been followed.

Damages resulting from operational faults cannot be acknowledged as warranty cases.

The products of the manufacturer have been developed and produced for specific applications. No warranty claim is accepted in case of non-compliance with the due employment according to the operating instructions, in case of the employment for other purposes than originally intended or the employment of inadequate accessories.

The periodical maintenance and cleaning of the products according to the directions of the operating instructions is absolutely necessary. The intervention of third persons (opening the machine) renders any warranty claim void.

Maintenance and cleaning operations cannot be claimed on the basis of warranty.

Make sure only original spare parts and original accessories are used. They are available at the authorized specialized product dealer. If non-original parts are used, consequential damages and increased hazard cannot be ruled out. The producer is not liable for such damages. Disassembled or partially disassembled hand saws and those repaired with non-original parts are excluded from the warranty.

Certain components, such as carbon brushes, ball bearings, switches, power-supply lines, gaskets, etc., are exposed to usage dependent or to normal wear. These wearing parts are not object of this warranty. Wearing parts are marked on the spare parts lists.

10.0 General safety instructions

1. Read and follow these instructions before you use the tool. Keep these safety instructions in a safe place.
2. Keep your workplace tidy. Untidiness in the workplace can cause accidents.
3. Protect yourself from electric shocks. Refer to the applicable regulations. Avoid physical contact with earthed parts, such as pipes, heaters, furnaces and refrigerators.
4. Keep children away. Do not allow other people to touch the tool or cable, keep them away from where you are working.
5. Keep your tools in a safe place. Unused tools should be kept in a dry, locked room out of the reach of children.
6. Do not overload your tool. It will work better and more safely in the specified capacity range.
7. Use the correct tool. Do not use tools that are too weak or mounted tools for heavy work. Do not use tools for purposes and work for which they have not been designed.
8. Wear suitable clothing. Do not wear excessively baggy clothing or jewellery, which may be caught by moving parts. For working outdoors, we recommend the use of rubber gloves and sturdy shoes. Wear a hairnet if you have long hair.
9. Use goggles. Use a breathing mask for work that generates dust.
10. Do not use the cable for any purpose other than that for which it is designed. Do not carry the tool by the cable and do not use it to pull the plug out of the socket. Protect the cable from heat, oil and sharp edges.
11. Check the connection lead and plug every time before you use the tool for signs of damage. If they are damaged, have them replaced by a specialist. Always keep the connection lead away from the working area of the machine.
12. Secure the workpiece. Use clamps or a vice to hold the workpiece. This will make it more secure that if you hold it in your hand and will allow you to use both hands to control the machine.
13. Do not overstretch yourself. Avoid abnormal body positions. Ensure that you have a stable area on which to stand and keep your balance at all times.
14. Look after your materials with care. Keep your tools sharp and clean so that they produce good safe results. Check the plug and cable at regular intervals and have them replaced by a specialist if they suffer any damage. Check the extension cable at regular intervals and replace damaged cables. Keep the handles free of oil and grease.
15. Disconnect the mains plug from the supply when the tool is not in use and when changing the tool.
16. Do not leave a tool spanner on the tool. Before switching on the tool check that the wrench and setting tools have been removed.
17. Avoid the machine starting when you do not intend it to. Do not carry a tool that is connected to the mains supply with your finger on the switch. Ensure that the switch is turned off when you connect the tool to the mains supply.
18. Electric tools outdoors and in wet areas: Mobile tools which are used outdoors should be connected to the mains supply using a residual-current circuit breaker or the like for added safety. This is particularly important when working with freehand tools. If there is a water supply, you should use an isolation transformer and a voltage supply of 115 V; please specify in your order.
19. For outdoors work, only use extension cables, which are approved for this purpose and marked accordingly.
20. Be vigilant at all times. Watch your work. Proceed sensibly. Do not use the tool if you are not concentrating fully on what you are doing.
21. Important:
Safety equipment (such as overcurrent protection devices, undervoltage trips, safety couplings etc.) are tools but do not offer guaranteed safety. As a responsible manufacturer we tailor these tools to each other so that they offer the best possible protection. But without the care and caution of the use, these tools may even cause damage if they are not used properly. Have the slip couplings, in particular, checked during the quarterly inspection to ensure that it is correctly adjusted and functions properly. This inspection should be conducted by the manufacturer or an authorised service outlet and documented.

22. Check the machine every day for signs of damage, conduct a visual inspection:
Before reusing the tool, carefully check the safety equipment or slightly damaged parts to ensure that they offer perfect and proper function. Check that all moving parts function correctly, that they do not jam and that none of the parts are damaged. All parts must be correctly fitted and satisfy all the conditions to ensure the perfect operation of the tool. Damaged safety equipment and parts must be repaired or replaced properly by a specialist service contractor. Do not use any tools, which cannot be switched on and off using the switch. Pay particular attention to ensuring electrical safety: Cables? Plugs? Switches? Do all the components satisfy safety regulations?
23. Repairs may only be completed by trained personnel. Before being used for the first time and after all repair work, the safety of electric tools must be checked by an electrician pursuant to VBG 4, § 5. This inspection must also be conducted and documented at regular intervals – at least once per year.
24. Please note that as the operator you are responsible for complying with any additional regulations. For example if electric tools are used in a wet and/or damp environment, the regulations of the "Stone and Earth" Professional Association must be satisfied.
25. Electrical safety and fire safety: We now also recommend the additional safety and fire safety for all out tools, as set out in the new version of VDE 0100 which can be achieved by using low cost residual current-operated circuit-breakers or DI/PRCD switches.

11.0 Spare parts list

11.1 Stone drilling machine complete

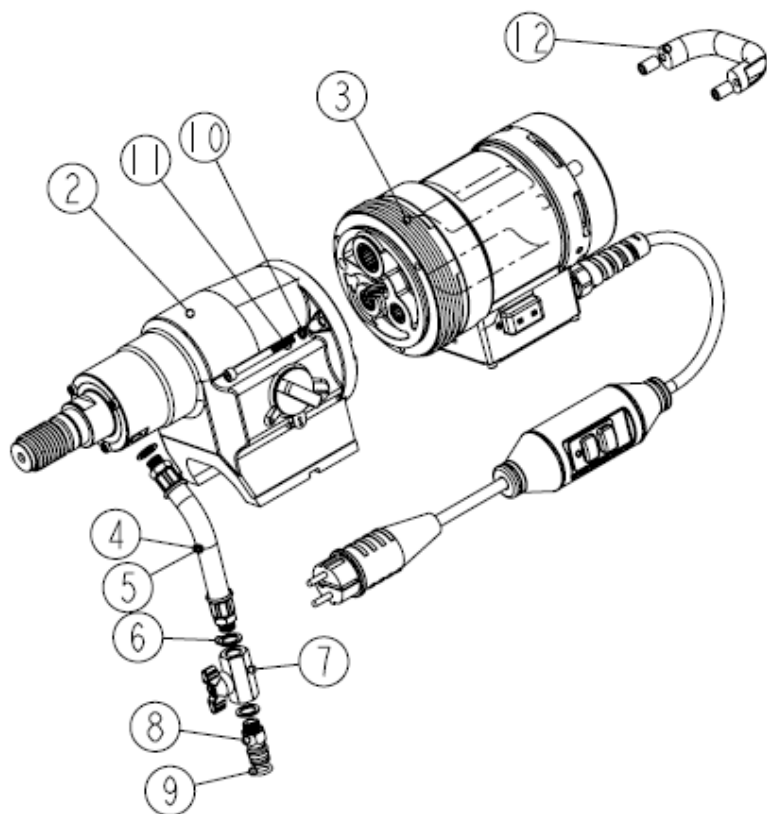

Item	Art. No.	Description	No.
1	200924	Stone drilling machine, complete	1
2	200895	Gear, complete	1
3	301342	Motor, complete	1
4	300074	Water connection, complete	1 **
5	800733	Hose, complete	1
6	800028	Sealing ring	3
7	800023	Ball cock, complete	1
8	800020	Nipple	1
9	800040	O ring	1
10	800077	Locking washer	3
11	900318	Allen bolt	5
12	302586	Handle	1
			Wearing parts **

11.2 Motor complete

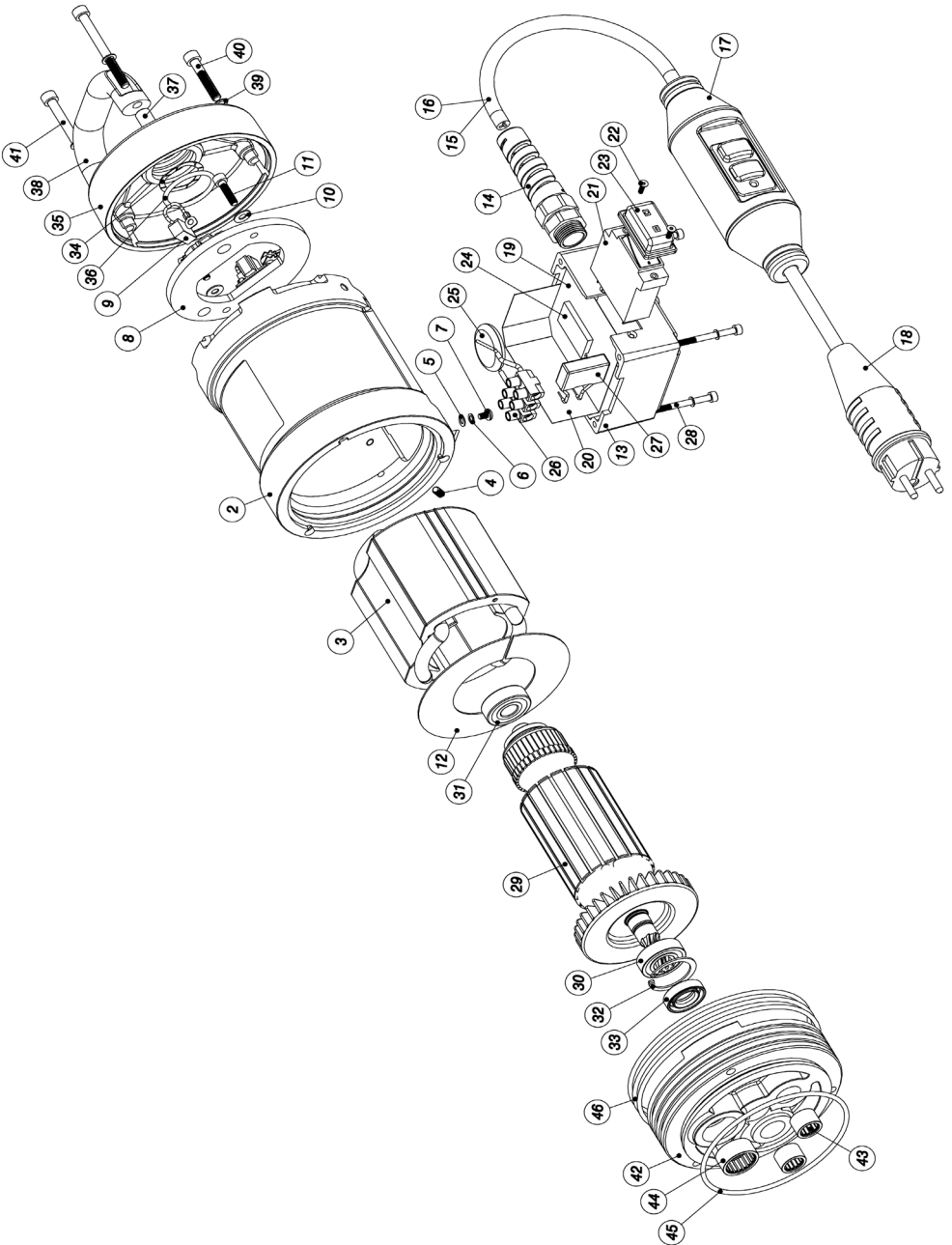

Item	Art. No.	Description	No.
1	300713	Motor complete	1
2	200839	Motor casing	1
3	401552	Magnet casing	1
4	900011	Set screw	1
5	900229	Washer	1
6	800076	Spring washer	5
7	900412	Slotted pan head screw	1
8	300030	Bush bridge	1
9	800063	Carbon brush	2 **
10	900180	Spring washer	2
11	900332	Hexagon socket head cap screw	2
12	400036	Air baffle disc	1
13	302099	Switch box	1
14	802733	Cable gland	1 **
15	801244	Connection cable complete	1 **
16	801245	Connection cable - M conf.	1
17	802658	Safety switch	1
18	801236	Connection cable - S conf.	1
15	801182	Connection cable complete codiert 1h optional	1
16	800583	Connection cable optional	1
17	900161	Plug 1h optional	1
19	402080	Isolation	1
20	402302	Isolation	1
21	801356	Toggle switch	1
22	900458	Countersunk screw	2
23	800174	Protective cap	1 **
24	401334	Cover plate	1
25	401118	Start-up current limiter, complete	1
26	401119	Lamp-wire connector	1
27	801354	Interference-suppression capacitor	1
28	900704	Hexagon socket head cap screw	4
29	400905	Armature	1
30	900483	Grooved ball bearings	1 **
31	900329	Grooved ball bearings	1 **
32	901094	Locking ring	1 **
33	900708	Shaft sealing ring	1 **
34	800122	Ball bearing compensating disc	1
35	300029	Bearing cap	1
36	800089	O-ring	1 **
37	900674	Sleeve	2
38	302586	Handle	1
39	800077	Spring washer	3
40	900312	Hexagon socket head cap screw	1
41	900318	Hexagon socket head cap screw	2
42	200379	Intermediate cover	1
43	900168	Needle sleeve	2 **
44	900156	Needle sleeve	1 **
45	800083	O-ring	1 **
46	800354	O-ring	3 **

Wearing parts**

11.3 Gear complete

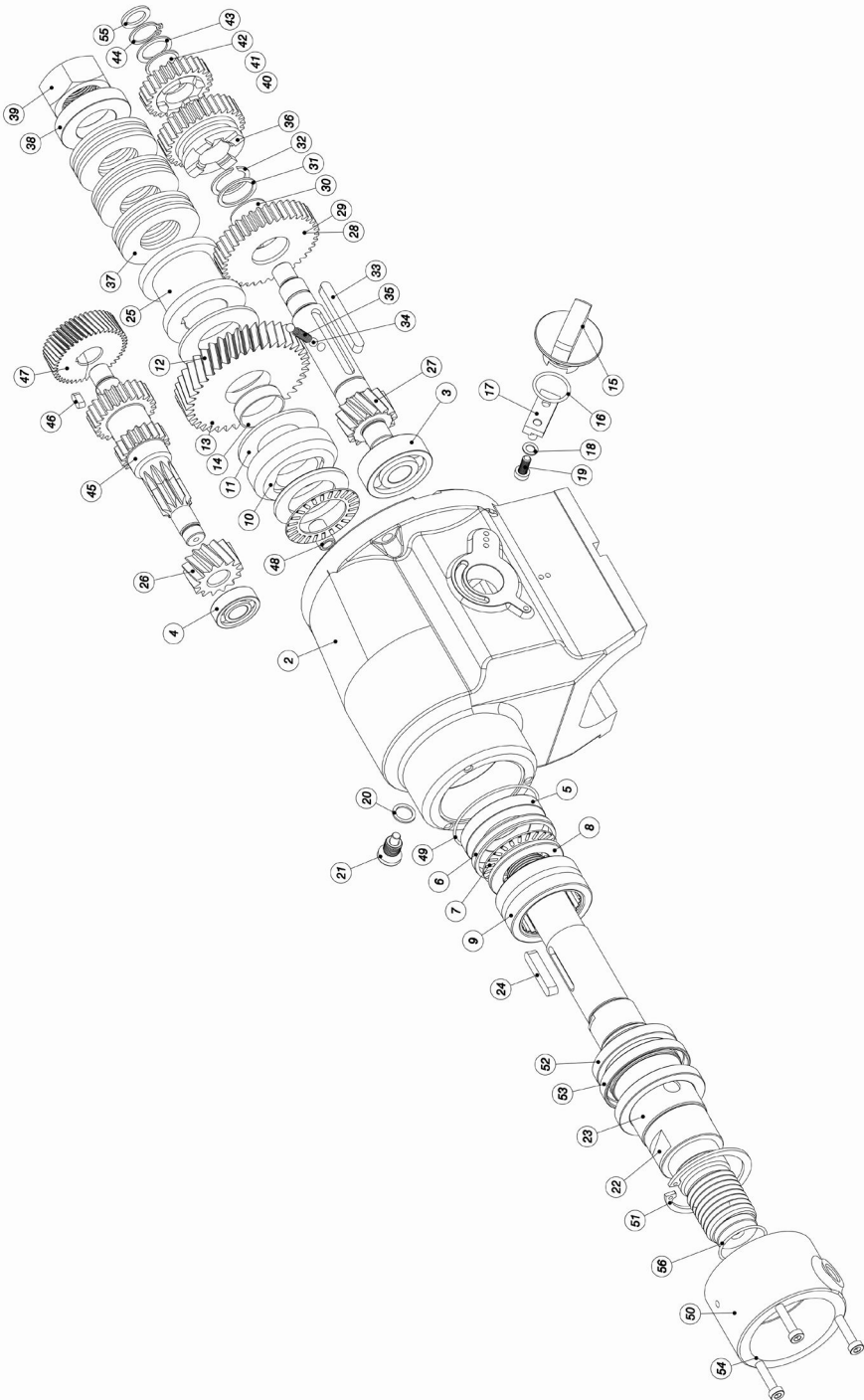

Item	Art. No.	Description	No.
1	200895	Gear, complete	1
2	100080	Gear casing	1
3	900051	Grooved ball bearings	1 **
4	900495	Grooved ball bearings	1 **
5	900670	Interim washer	1
6	400795	Sleeve	1
7	900669	Axial needle rim	2 **
8	900672	Rotor disc	2 **
9	900671	Needle bearing	1 **
10	300670	Support disc	1
11	400011	Brake disc	2 **
12	401308	Floor wheel, complete	1
13	301051	Floor wheel	1
14	400798	Bearing sleeve	1 **
15	400048	Gear change shaft, complete	1
16	800097	O ring	1 **
17	400096	Gear change lever, complete	1
18	800075	Locking disc	1
19	900354	Allen bolt	1
20	900500	Sealing ring	1 **
21	401637	Sealing screw complete	1
22	301934	Drill spindle, complete	1
22	301220	Drill spindle complete – Asian optional	1
23	401964	Wave protection sleeve	1
23	400002	Wave protection sleeve optional	3
24	900110	Adjusting spring	1
25	400796	Bridge sleeve	1
26	300427	Pump wheel	1
27	301052	Pinion shaft	1
28	401310	Loose wheel 1, complete	1
29	301053	Loose wheel 1	1
30	400082	Bearing sleeve 1	1 **
31	400129	Adjusting washer	1
32	800080	Spring ring	1 **
33	900504	Adjusting spring	1
34	900014	Ball	2
35	800165	Bridge spring	1
36	301054	Gear change wheel	1
37	900663	Disc spring	9
38	401965	Compensation slice	1
39	401966	Hexagonal nut	1
40	401311	Loose wheel 2, complete	1
41	301055	Loose wheel 2	1
42	400083	Bearing sleeve 2	1 **
43	900163	Adjusting washer	1
44	900209	Locking ring	1 **
45	300872	Reduction gear shaft	1
46	900127	Adjusting spring	1
47	401338	Reduction gear wheel	1
48	900674	Bush	1
49	801059	O ring	1 **
50	400797	Connection ring	1
51	800760	Locking ring	1 **
52	900673	Shaft seal	1 **
53	900027	Shaft seal	2 **
54	900675	Allen bolt	3
55	900503	Adjusting washer	1
56	800092	O ring	1 **
57	801019	Gear lubricant oil 0,3 l	1 **

Wearing parts **

11.4 Connection cables and accessories

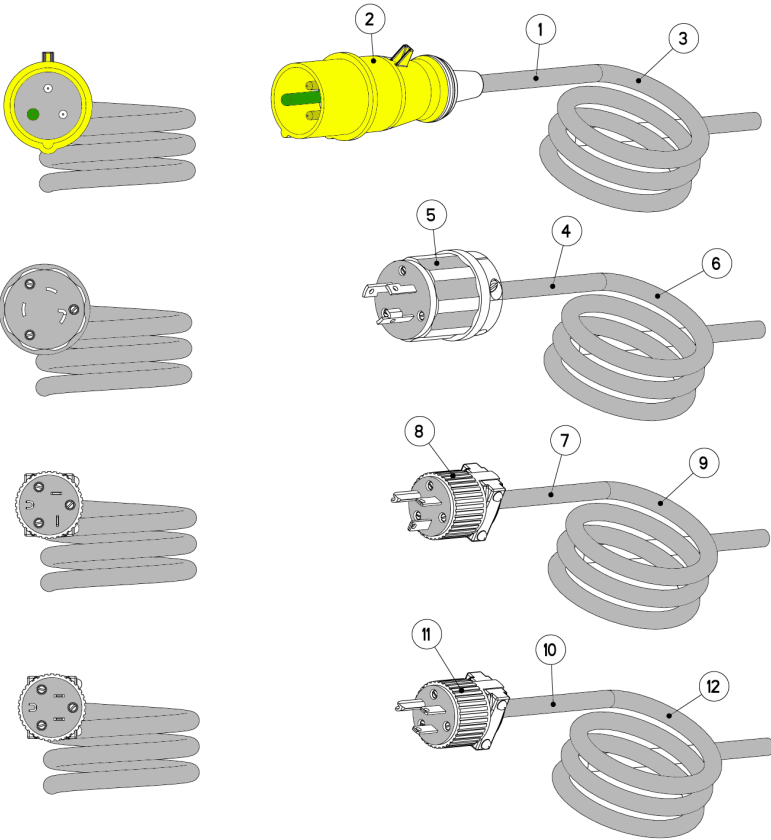

Item	Article number	Description	No.
Plugs for UK and standards for type EBM			
1	801462	Connection cable compl. 4h	1
2	900159	Plug, 4h	1
3	801328	Connection cable, finished	1
Plugs for UK and standards for type BBM			
1	801460	Connection cable compl. 4h	1
2	900159	Plug, 4h	1
3	801459	Connection cable, finished	1
Plugs for USA and Japan up to 30 amps for type BBM			
4	801321	Connection cable compl.	1
5	801317	Plug, 30A	1
6	801320	Connection cable, finished	1
Plugs for USA and Japan up to 20 amps for type EBM			
7	801461	Connection cable compl.	1
8	800200	Plug, 15A	1
9	801328	Connection cable, finished	1
Plugs for USA and Japan up to 20 amps for type EBL			
7	803182	Connection cable compl.	1
8	800168	Plug, 20A	1
9	801328	Connection cable, finished	1
Plugs for Australia			
10	802839	Connection cable compl.	1
11	801809	Plug, 15A	1